

THIS DRAWING IS UNPUBLISHED. RELEASED FOR PUBLICATION MAR ,2006.  
 © COPYRIGHT 2006 BY TYCO ELECTRONICS CORPORATION. ALL RIGHTS RESERVED.

LOC	DIST	REVISIONS					
E	B	P	LTR	DESCRIPTION	DATE	DWN	APVD
		A		FIRST ISSUE	20MAR06	JMS	FWK

- NOTES**
- 1 100 TRAY PACK IN ACCORDANCE WITH AMP SPEC 107-3275
  - 2 SINGLE PACK IN ACCORDANCE WITH AMP SPEC 107-3275
  - 3 Au PLATING
  - 4 Ni PLATING
5. CHARACTERISTICS  
 FREQUENCY RANGE: DC-4GHz  
 INSULATION RESISTANCE: 5000 MOHMS  
 WORKING VOLTAGE: 500V  
 DIELECTRIC WITHSTAND VOLTAGE: 1500V RMS  
 TEMPERATURE RATE: -55°C TO +85°C  
 CONTACT RESISTANCE: 3 mOHMS
6. MECHANICAL CHARACTERISTICS  
 DURABILITY: 50 CYCLES
7. FOR TECHNICAL DATA REFER TO YOUR LOCAL TYCO ELECTRONICS SALES OFFICE
8. ALL DIMENSIONS ARE NOMINAL FOR REFERENCE ONLY UNLESS OTHERWISE STATED

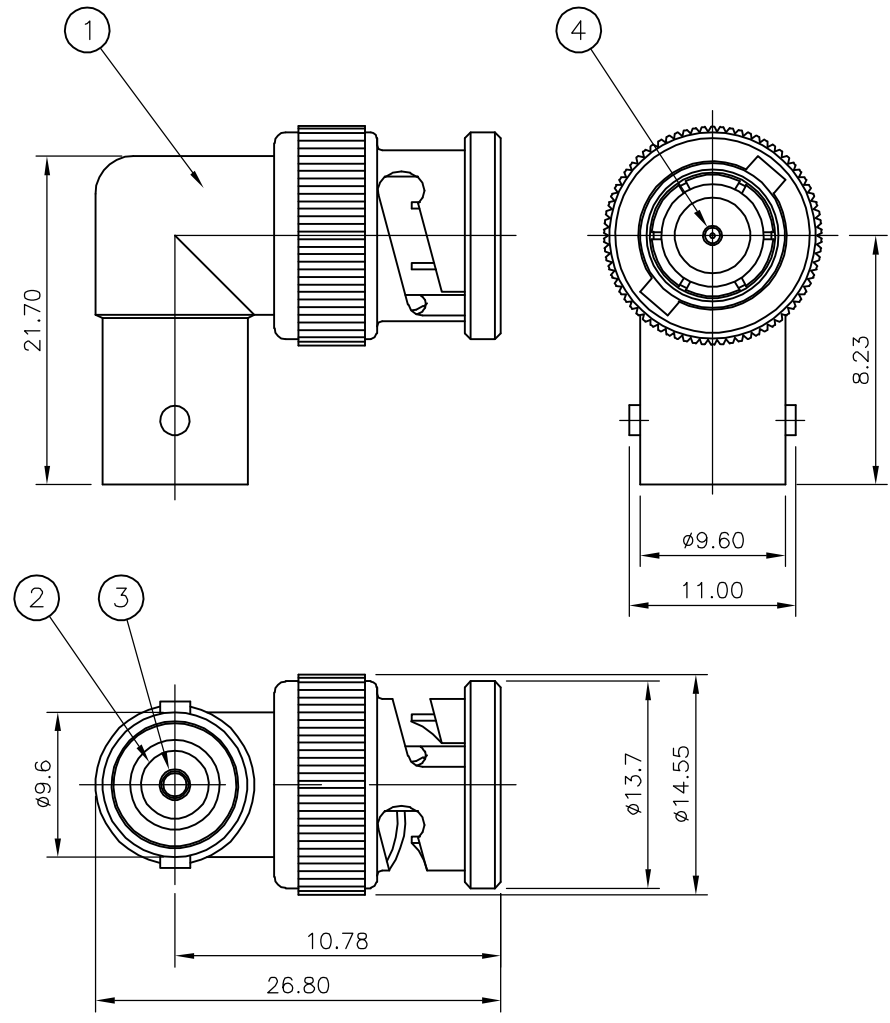

QTY	QTY	MATERIAL	DESCRIPTION	ITEM
1	1	PHOS BRONZE 3	MALE CONTACT	4
1	1	PHOS BRONZE 3	FEMALE CONTACT	3
1	1	POLYMETHYLPENTENE	INSULATOR	2
1	1	ZINC ALLOY 4	BODY	1
5--1	5--0			
QUANTITY PER ASSY				PARTS LIST

THIS DRAWING IS A CONTROLLED DOCUMENT.		DWN J.SANDWELL 20MAR06	Tyco Electronics Corporation Bideford, UK, EX39 4HE	
DIMENSIONS: mm		CHK S.PARLOW 20MAR06		
TOLERANCES UNLESS OTHERWISE SPECIFIED:		APVD F.WHEELER-KING 20MAR06	NAME BNC ELBOW ADAPTOR PLUG - JACK	
0 PLC ± - 1 PLC ± - 2 PLC ± - 3 PLC ± - 4 PLC ± - ANGLES ± -		PRODUCT SPEC -	50 OHMS	
MATERIAL SEE TABLE		FINISH -	APPLICATION SPEC -	RESTRICTED TO -
		WEIGHT -	SIZE A3	CAGE CODE 00779
			DRAWING NO C-1634526	
CUSTOMER DRAWING			SCALE NTS	SHEET 1 OF 1
			REV A	